

# **Standard Subdivision Requirements for Works Owned by MainPower**

The information contained herein is confidential to MainPower and may not be reproduced without express permission.



# Contents

- 1. Overview .....3**
- 2. Responsibilities .....3**
  - 2.1 The Responsibilities of the Developer, or his agent, include:..... 3
  - 2.2 The Responsibilities of MainPower include: ..... 3
- 3. On-Site Commencement .....3**
- 4. Streetlighting .....3**
- 5. Cable Trenches.....4**
  - 5.1 Evacuation Requirements ..... 4
  - 5.2 Clearance from Other Services ..... 5
  - 5.3 Clearance from Trees ..... 5
  - 5.4 Bedding..... 6
  - 5.5 Mechanical Protection ..... 6
  - 5.6 Warning Strip ..... 6
  - 5.7 Ducts..... 6
  - 5.8 Final Inspection Before Backfilling ..... 6
  - 5.9 Variations ..... 6
  - 5.10 Typical Cable Trench Arrangement..... 7
- 6. Document History and Version Control.....8**
- 7. Distribution.....8**

## 1. Overview

This document is designed to provide a developer with the information required to have a new subdivision connected to the MainPower electricity network.

## 2. Responsibilities

### 2.1 The Responsibilities of the Developer, or his agent, include:

- Provision of a base map in AutoCAD dwg format. The map shall include all boundaries, kerbs, footpaths and connections with the adjacent roading network.
- Obtaining all required consents and clearances from all relevant authorities and affected parties.
- Cable trenching and backfill, the installation of all ducts for MainPower cables, including the installation of mag slab and cable warning strip, and the provision of as-built drawings for all ducts installed. (Ducts, mag slab and warning tape to be collected from MainPower store)
- Provision of suitable site(s) for any substation/s that may be required.
- The design of any streetlighting installation that may be required.
- Supply and storage of any required streetlights.
- Payment of required deposit prior to start of work.

### 2.2 The Responsibilities of MainPower include:

- Preparation of design documentation for the electrical reticulation required for the development.
- Supply of all electrical ducting, mag slab and warning tape that may be required.
- Supply and installation of electrical cabling in developer supplied trenches.
- Quality control of backfilling of power trenches.
- Installation of developer supplied street lights.
- Supply and installation of substations, link boxes, service boxes and any other equipment required to complete the electrical reticulation for the development.

## 3. On-Site Commencement

- No work will start on site until a signed acceptance of MainPower's quotation has been received by MainPower and any required deposit has been paid.
- Following acceptance of MainPower's quotation a Construction Co-ordinator will be appointed to co-ordinate the work. Prior to the commencement of the work the developer must arrange an on-site meeting with the Construction Co-ordinator to discuss the work programme and the plans and specifications.
- An estimated lead time for the work to commence will be given at the time of the initial application for supply to the subdivision. The lead time will be confirmed at the time of the initial on-site meeting to discuss the programme. No work will be programmed until the site meeting has been held.
- Changes to the construction programme and/or delays in trenches being available may mean that the work will need to be re-scheduled, which may result in significant delays.

## 4. Streetlighting

- MainPower will install any required streetlights, but does not undertake the design of the streetlighting.
- The Developer is responsible for arranging the design for any required streetlighting.
- It is the Developer's responsibility to purchase and arrange storage for any required streetlights.

## 5. Cable Trenches

Prior to any cables being installed kerbs and boundary pegs shall be in place and final ground levels marked. MainPower will take no responsibility for the incorrect installation of cables due to incorrect marking, or lack of marking, of boundaries and/or levels.

### 5.1 Evacuation Requirements

Trenches shall be excavated and cables shall be covered as per the table below. All trench depths are to be based on finished ground levels. These trench depths will allow suitable bedding and protection to be applied around the cable.

Location	Low Voltage		High Voltage	
	Trench Depth	Min. Cover	Trench Depth	Min. Cover
Along the side of roads	750 mm	600 mm	950 mm	800 mm
Road crossings and private property easements	950 mm	800 mm	1150 mm	1000 mm

In all cases minimum cover takes priority over trench depth, so that a trench may need to be excavated to a greater depth to achieve the necessary minimum cover if additional sand is required.

MainPower must approve all situations where the above trench depths cannot be met (e.g. rocky ground, installation with other services).

The trench shall be as straight as possible and shall be parallel to the road boundary. All road crossings shall be perpendicular to road boundaries / kerb line.

Cables shall be maintained within  $\pm 50$  mm of the offsets shown on the Design Drawings. No significant variation is allowed unless agreement is reached with the MainPower representative. Unless specified otherwise, standard offsets shall be:

- 0.6 m from the boundary in urban areas, and
- 1.0 m from the boundary in rural areas.

Unless shown otherwise on the Design Drawings, cables shall be threaded under service pipes, Telecom cables or other obstructions, and clearances from other services shall be maintained as per the following table (all dimensions in mm):

## 5.2 Clearance from Other Services

The clearances in the following table are minimums and may need to be increased based on a site risk assessment, criticality of the cable asset(s), or thermal sensitivity of highly loaded cables.

### Minimum clearance requirements between electrical cables and other services:

Clearance between electrical cable and:	Vertical Clearance (mm)	Horizontal Clearance (mm)
Electrical (where either cable is 33 kV or higher)	500 <sup>a</sup>	1000 <sup>a</sup>
Electrical (where both cables are LV, 11 kV or 22 kV)	100 <sup>b</sup>	300 <sup>b</sup>
Telecommunications	150 <sup>d</sup>	450 <sup>c, d</sup>
Fresh Water	50	500 <sup>e</sup>
Sewer and Stormwater	50	500
Gas	150	300

<sup>a</sup> Site-specific engineering confirmation is required

<sup>b</sup> Site-specific engineering confirmation is required within 100 m of a substation and for highly loaded feeder cables

<sup>c</sup> Clearance may be reduced to 300 mm for LV neutral-screened or armoured electrical cable

<sup>d</sup> Hazardous voltages may still be induced on telecommunications equipment in an electrical fault. Site specific assessment may be required.

<sup>e</sup> Clearance may be reduced to 300 mm for water pipes up to 70 mm diameter

A MainPower representative shall be on site when trenching within 2 m of 66 kV or 33 kV cables.

## 5.3 Clearance from Trees

Where a cable is to be laid within the clearance distance (see following table) of an existing tree MainPower will require the cable to be installed in a 100/150 mm duct extending 1.5 m either side of the centre of the tree. The duct shall be installed with a minimum of 1.2 m cover.

If trees are to be planted adjacent to cables that have already been laid and within the clearance distances specified in the table below a root barrier will need to be installed.

The root barrier is to be Amoco 4550 or equivalent to a depth of 1.3 m. Preferably the barrier is to surround the root pit and the joint is to be sealed. As an alternative a 3.0 m length of barrier may be placed between the cable and the tree extending parallel to the cable for 1.5 m either side of the centre of the tree to a depth of 1.3 m.

Cable Barrier – Tree Clearances				
Cable voltage (kV)	66	33	11 / 22	0.4
Minimum tree clearance without barrier (m)	5.0	5.0	3.0	2.0
Minimum tree clearance with barrier (m)	2.5	2.5	1.0	1.0
Minimum cable to barrier clearance (m)	2.0	2.0	0.3	0.3

#### 5.4 Bedding

In good soil conditions, bedding material may not be required, however where the ground conditions include coarse material liable to cause damage to cables, then a minimum bedding and all round cable cover of 50 mm of well tamped sieved earth, sand or other backfill material approved by MainPower shall be provided. This fill shall be placed in a dry trench with excess water removed.

The requirement for bedding shall be confirmed with the Construction Co-ordinator.

#### 5.5 Mechanical Protection

Mechanical protection comprising plastic slabs (Magslab) shall be placed centrally over all cable laid<sup>1</sup>.

In the event that the required cover cannot be achieved the MainPower Construction coordinator shall be consulted over a suitable, alternative, mechanical protection.

<sup>1</sup> Mechanical protection is not required for Low Voltage Neutral Screen cables

#### 5.6 Warning Strip

Plastic cable warning strip shall be placed over all cable at an approximate depth of 300 mm below finished ground level.

#### 5.7 Ducts

All cable ducts associated with the development shall be installed as specified on the Design Drawings. The installation of cable ducts shall include the installation of the associated mag slab and warning tape.

All joints in ducts shall be glued with a suitable PVC cement.

Ducts shall be installed to comply with the minimum ground cover specified for cables in the table above.

Duct sizes will be as specified on the Design Drawings, however generally ducts shall be 100 mm diameter for commonly used cables (including communications or pilot cables). Only one distribution cable shall be installed per duct. Streetlighting cables may be run in the same duct as a distribution cable providing the distribution cable is run first.

All power ducts, mag slab and warning tape will be supplied by MainPower and shall be collected from the MainPower store by the Developer, or their agent.

All ducts shall be handled and installed in accordance with AS\NZS 2566.2 *Buried Flexible Pipelines – Installation*. Cable ducts shall as far as possible be laid horizontal, in straight lines, parallel to or at right angles to kerbs and/or property boundaries as shown on the Design Drawings. Ducts shall only be laid with bends with the prior approval of MainPower's representative. The inside surface shall be clean and duct ends shall be capped to prevent material entering. Where specified a draw-wire shall be installed to facilitate ease of future installation.

Legible as-built drawings shall be supplied showing the location of all MainPower ducts installed by the Developer. MainPower sign off of the power installation will be provided until all required as-built drawings have been provided.

#### 5.8 Final Inspection Before Backfilling

The Developer shall notify the MainPower representative prior to backfilling any trenches.

MainPower reserves the right to make the contractor open cable trenches for inspection where adequate notification has not been received.

The contractor shall allow access to all parts of the site at all reasonable times to MainPower's inspector to allow auditing of the work.

#### 5.9 Variations

Relocation work resulting from the incorrect marking, or lack of marking, of boundaries and/or levels will be carried out at the developer's cost and no work will be started until the variation costs have been accepted in writing.

If MainPower staff arrive on site to lay cables and the trench is not ready at the time promised a variation will apply and the work will need to be rescheduled.

Variations that are additional to the original construction programme will need to be rescheduled and depending on how full the schedule is there may be a delay to the completion of the work.

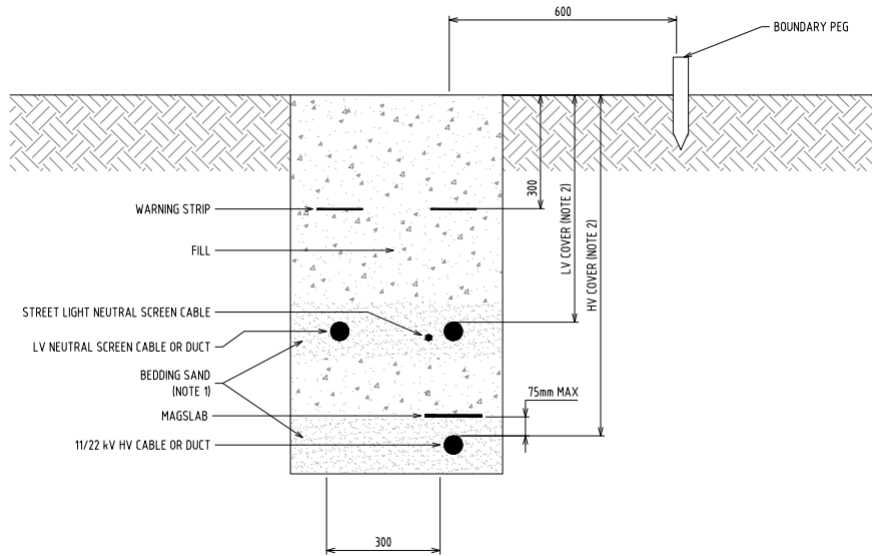

### 5.10 Typical Cable Trench Arrangement

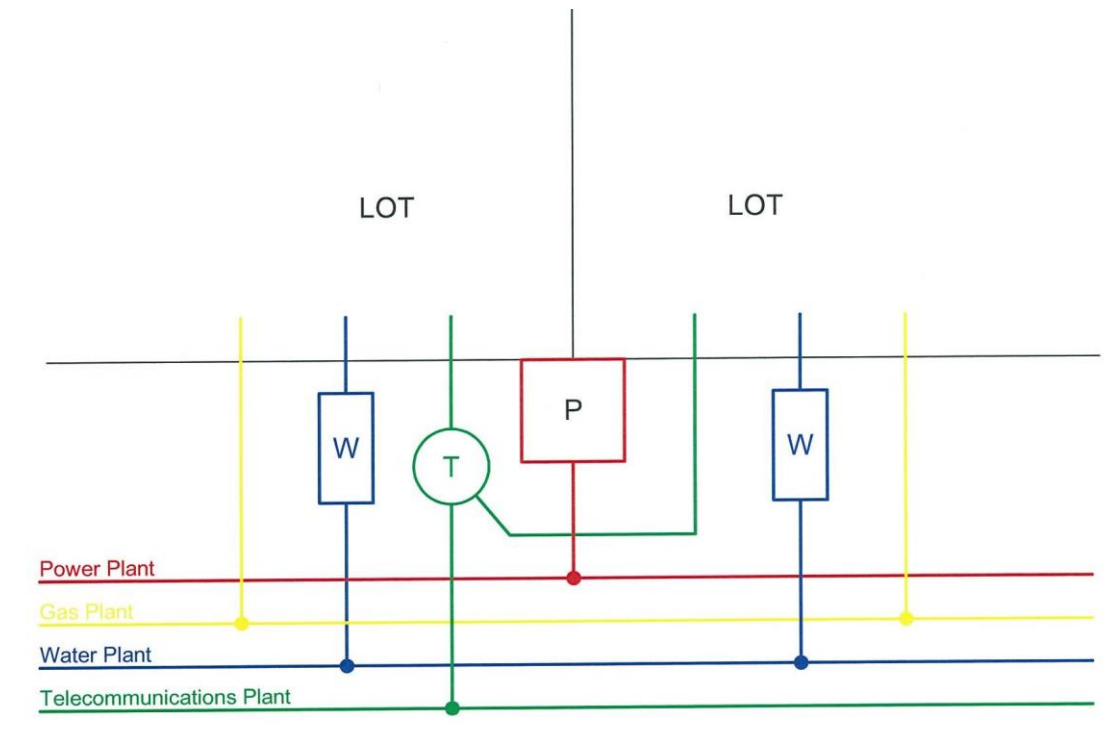

## 6. Document History and Version Control

Version #	Date Approved	Approved By	Brief Description
1.0	14.11.13	Network Management Distribution	First issue Updated to new template 28.09.15
2.0	05.05.22	Engineering & Design Manager	Requirements of Low Voltage Neutral Screen cable added Updated and clarified clearances between cables and other services Minor edits

## 7. Distribution

- All staff